

Quick change tapping chucks with length compensation on compression and expansion
 Mandrins de taraudage à changement rapide avec compensation longitudinale à la compression et traction



Verwendung:
 Zur Aufnahme von Schnellwechsel-Einsätzen für Gewindebohrer.

Application:
 For the chucking of quick change adaptors for taps.

Application:
 Pour le serrage d'adapteurs porte-tarauts à changement rapide.

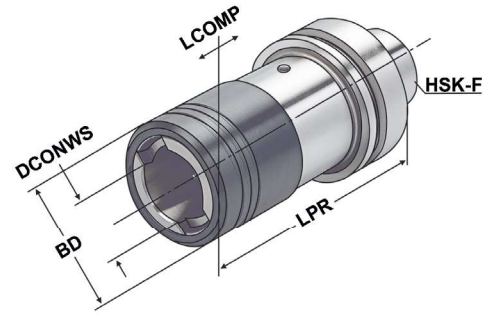

5

Bestell-Nr. Order no. Référence	HSK	Spannbereich Capacity Capacité	SZID	DCONWS	LPR	BD	LCOMP
F63.16.12	HSK-F 63	M3 - M14	1	19	102	36	7
F63.16.20	HSK-F 63	M5 - M22	2	31	140	53	12

Hinweis: Für Bearbeitungszentren ohne Synchronspindel.
Note: For machining centres without synchronous spindle.
Observation: Pour centres d'usinage sans broche synchrone.

